



Maxx Cold Select Series | The Legacy Companies
 3355 Enterprise Avenue, Suite 160, Fort Lauderdale, FL 33331
 (954) 202-7419 • Fax (954) 202-7337 • (877) 600-8401
 www.MaxximumFoodService.com • Info@MaxxColdFoodService.com

Project Name: _____
 Location: _____
 Item #: _____ Qty: _____
 Model: _____

SANDWICH/SALAD STATIONS

Model: MXSR29S 1 Door MXSR48S 2 Door MXSR60S 2 Door

International Model:
 Add -50 (220V/50Hz/1Ph)



MXSR60S Shown

Maxx Cold Select Series Sandwich Stations provide the perfect blend of durability and accessibility to allow for quicker and easier preparation of sandwiches, salads and more at a value price. Hinged food covers keep the food well contents fresh and cool throughout the day. A high quality stainless steel exterior allows for easy cleaning. If properly maintained, this appliance will provide years of reliable, cost effective performance.

FEATURES

- Solid stainless steel doors with easy to grip, formed drawer handles
- 4 Casters (2 locking, 2 non-locking)
- Adjustable, heavy-duty wire shelves (1 per section/door)
- Comes with removable, reversible cutting board
- Integrated condensate evaporator pan eliminates the need for a floor drain connection
- Available in various lengths/capacities to suit your storage and layout needs
- Comes standard as 120V/60Hz (220V/50Hz & 220V/60Hz voltage options are available)

TEMPERATURE

- Holding temperature: 33° to 41°F (1° to 5°C)
- Utilizes environmentally friendly refrigerant R290A
- Efficient, forced-air refrigeration system
- Readily adjustable solid state control scheme with digital temperature display

CONSTRUCTION

- Exterior Material: Durable, easy to clean stainless steel
- Interior Material: Easy to clean painted aluminum
- Environmentally friendly, CFC-free urethane foam insulated walls and doors
- Dart style magnetic compression gaskets are replaceable without requiring tools
- Heavy duty epoxy coated shelves for easy access and minimal maintenance without disrupting air flow
- Open well is designed to hold 1/3, 1/2 or Full Size pans without requiring adapters
- Open well includes slots for industry standard adapter bars to allow use of 1/6 pans

REFRIGERANT

Environmentally-friendly R-290A, with the lowest global warming potential value (3) of any commercially available refrigerant used today

ELECTRIC

115/60Hz/1 Ph (NEMA 5-15)
 (additional voltage options are available)
 Cord set includes plug & 9.8' (3m) cord

1.27" / 32 mm

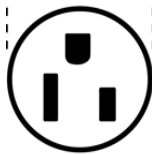

NEMA 5-15P



Certified to
ANSI NSF 7



Certified to
ANSI UL 471



DOE 2017
Compliant

Maxx Cold Select Series WARRANTY (USA / CANADA)

One (1) year parts
 One (1) year on-site labor
 Four additional (4) years compressor (part only)
 Administered by The Legacy Companies, 877.368.2797
 24/7 tech support provided

Due to periodic changes in designs, methods, procedures, policies and regulations, the specifications contained in this sheet are subject to change without notice. While we exercise good faith efforts to provide information that is accurate, we are not responsible for errors or omissions in information provided or conclusions reached as a result of using the specifications. By using the information provided, the user assumes all risks in connection with such use.

The built in performance enhancing functions ensure that given proper attention and preventative maintenance, each Maxx Product will deliver years of trouble free, reliable, low maintenance, efficient operation.

11/14/17 08:44



Maxx Cold Select Series | The Legacy Companies
 3355 Enterprise Avenue, Suite 160, Fort Lauderdale, FL 33331
 (954) 202-7419 • Fax (954) 202-7337 • (877) 600-8401
 www.MaxximumFoodService.com • Info@MaxxColdFoodService.com

SANDWICH/SALAD STATIONS

MXSR29S

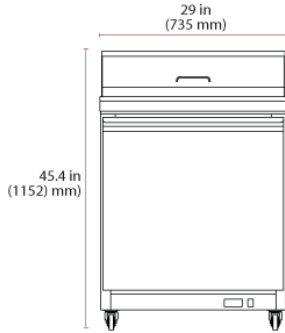

MXSR48S

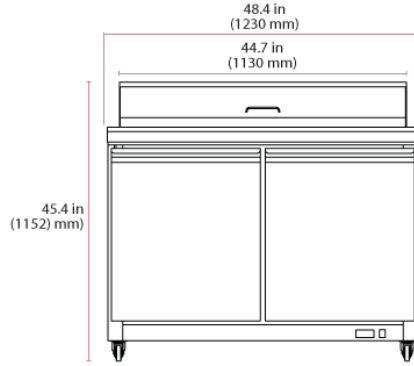

MXSR60S

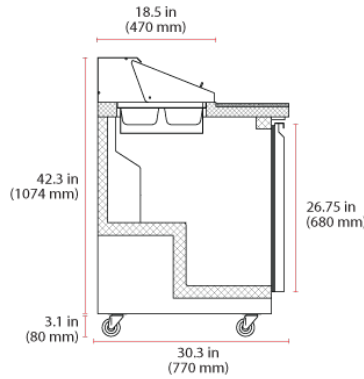
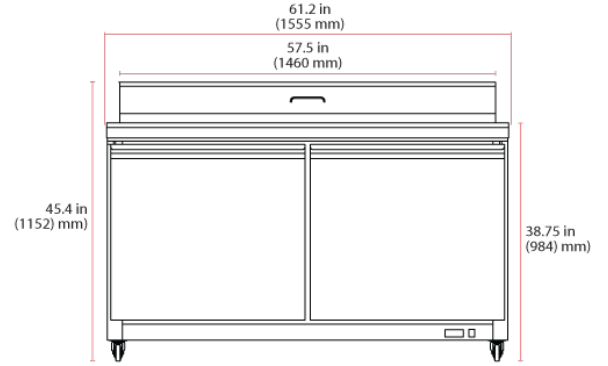

*Shorter or taller optional caster sets are available to suit your application requirements

	Exterior Dimensions in / mm	Interior Dimensions in / mm	Depth With Door(s) Open in / mm	Storage Capacity	Temperature Range	Voltage	Average Amp Draw	Shelves	Pan Capacity 1/3 (1/6)	Unit Weight
MXSR29S	29 x 30.3 x 45.4 735 x 770 x 1152	24 x 25 x 26.6 610 x 636 x 676	58 / 1473	7.59 Cu Ft 215 L	33° to 41°F 1° to 5° C	115V/60Hz	3.6	1	4 (8)	150 lb 68 kg
MXSR48S	48.4 x 30.3 x 45.4 1230 x 770 x 1152	43.5 x 25 x 26.6 1105 x 636 x 676	53 / 1346	13.77 Cu Ft 390 L	33° to 41°F 1° to 5° C	115V/60Hz	4.3	2	6 (12)	256 lb 116 kg
MXSR60S	61.2 x 30.3 x 45.4 1555 x 770 x 1152	56.3 x 25 x 26.6 1430 x 636 x 676	59.5 / 1511	17.83 Cu Ft 505 L	33° to 41°F 1° to 5° C	115V/60Hz	5.6	2	8 (16)	298 lb 135 kg

Due to periodic changes in designs, methods, procedures, policies and regulations, the specifications contained in this sheet are subject to change without notice. While we exercise good faith efforts to provide information that is accurate, we are not responsible for errors or omissions in information provided or conclusions reached as a result of using the specifications. By using the information provided, the user assumes all risks in connection with such use.