



Maxx Cold Select Series | The Legacy Companies  
 3355 Enterprise Avenue, Suite 160, Fort Lauderdale, FL 33331  
 (954) 202-7419 • Fax (954) 202-7337 • (877) 600-8401  
 www.MaxximumFoodService.com • Info@MaxxColdFoodService.com

Project Name: \_\_\_\_\_  
 Location: \_\_\_\_\_  
 Item #: \_\_\_\_\_ Qty: \_\_\_\_\_  
 Model: \_\_\_\_\_

# PIZZA PREPARATION TABLES

Model:  MXSPP50 1 Door     MXSPP70 2 Door     MXSPP92 3 Door

International Model:  
 Add -50 (220V/50Hz/1Ph)



MXSPP50



MXSPP70



MXSPP92

Maxx Cold Select Series Pizza Preparation Tables provide users with a reliable and efficient way to quickly prepare pizzas and provide an unbeatable value. The hinged closable food covers keep the food well contents fresh and cool during off-peak hours. A stainless steel exterior ensures durability and years of reliable service, while the unit's foam insulation and forced air cooling system deliver an outstanding food storage environment.

### FEATURES

- Solid stainless steel doors with easy to grip, integrated recessed drawer handles
- 4 Casters (2 locking, 2 non-locking)
- Adjustable, heavy-duty wire shelves (1 per section/door)
- Comes with removable cutting board (pizza topping rail with matching catch pan is an available option)
- Integrated condensate evaporator pan eliminates the need for a floor drain connection
- Available in various lengths/capacities to suit your storage and layout needs
- Comes standard as 120V/60Hz (220V/50Hz & 220V/60Hz voltage options are available)

### TEMPERATURE

- Holding temperature: 33° to 41°F (1° to 5°C)
- Utilizes environmentally friendly refrigerant R290A
- Efficient, forced-air refrigeration system
- Readily adjustable solid state control scheme with digital temperature display

### CONSTRUCTION

- Exterior Material: Durable, easy to clean stainless steel
- Interior Material: Coated aluminum
- Environmentally friendly, CFC-free urethane foam insulated walls and doors
- Standard recessed door handles
- Heavy duty epoxy coated shelves for easy access and minimal maintenance without disrupting air flow
- Front-accessed utility compartment for easy maintenance & effective air movement to properly cool the condensing unit
- Easily replaceable dart-style magnetic compression gaskets

### REFRIGERANT

Environmentally-friendly R-290A, with the lowest global warming potential value (3) of any commercially available refrigerant

### ELECTRIC

115/60Hz/1 Ph (NEMA 5-15)  
 (additional voltage options are available)  
 Cord set includes plug & 9.8' (3m) cord

1.27" / 32 mm

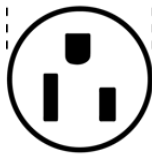

NEMA 5-15P



Certified to  
ANSI NSF 7



Certified to  
ANSI UL 471



DOE 2017  
Compliant

### Maxx Cold Select Series WARRANTY (USA / CANADA)

One (1) year parts  
 One (1) year on-site labor  
 Four additional (4) years compressor (part only)  
 Administered by The Legacy Companies, 877.368.2797  
 24/7 tech support provided

Due to periodic changes in designs, methods, procedures, policies and regulations, the specifications contained in this sheet are subject to change without notice. While we exercise good faith efforts to provide information that is accurate, we are not responsible for errors or omissions in information provided or conclusions reached as a result of using the specifications. By using the information provided, the user assumes all risks in connection with such use.

The built in performance enhancing functions ensure that given proper attention and preventative maintenance, each Maxx Product will deliver years of trouble free, reliable, low maintenance, efficient operation.



# MAXX COLD SELECT SERIES

Maxx Cold Select Series | The Legacy Companies  
3355 Enterprise Avenue, Suite 160, Fort Lauderdale, FL 33331  
(954) 202-7419 • Fax (954) 202-7337 • (877) 600-8401  
www.MaxximumFoodService.com • Info@MaxxColdFoodService.com

## PIZZA PREPARATION TABLES

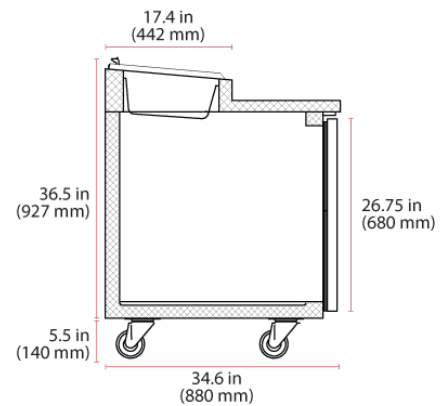
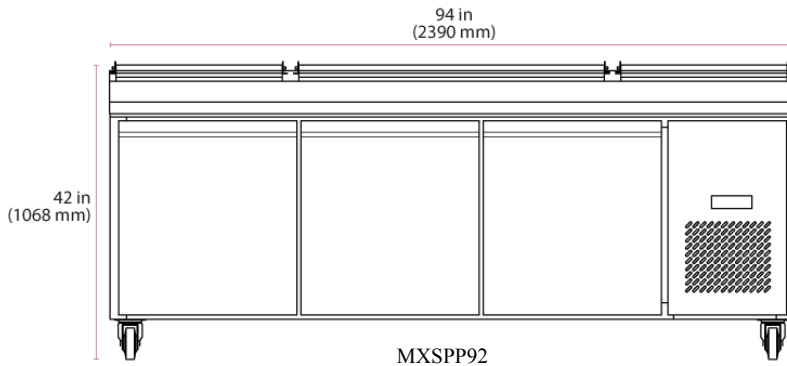
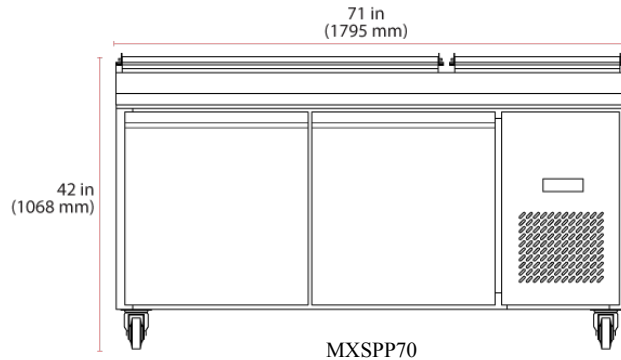
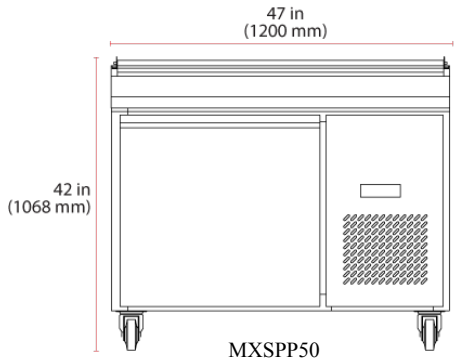

\*Shorter or taller optional caster sets are available to suit your application requirements

	Exterior Dimensions in / mm	Interior Dimensions in / mm	Depth With Door(s) Open in / mm	Storage Capacity	Temperature Range	Voltage	Average Amp Draw	Shelves	Pan Capacity 1/3 (1/6)	Unit Weight
<b>MXSPP50</b>	47 x 34.6 x 42 1200 x 880 x 1068	25.6 x 27.8 x 26.5 650 x 707 x 672	61 / 1549	10.95 Cu Ft 310 L	33° to 41°F 1° to 5° C	115V/60Hz	4	1	6 (12)	201 lb 91 kg
<b>MXSPP70</b>	71 x 34.6 x 42 1795 x 880 x 1068	49 x 27.8 x 26.5 1245 x 707 x 672	56 / 1422	20.91 Cu Ft 592 L	33° to 41°F 1° to 5° C	115V/60Hz	5.8	2	9 (18)	342 lb 155 kg
<b>MXSPP92</b>	94 x 34.6 x 42 2390 x 880 x 1068	72.4 x 27.8 x 26.5 1840 x 707 x 672	62.5 / 1588	30.87 Cu Ft 874 L	33° to 41°F 1° to 5° C	115V/60Hz	5.8	3	12 (24)	485 lb 220 kg

Due to periodic changes in designs, methods, procedures, policies and regulations, the specifications contained in this sheet are subject to change without notice. While we exercise good faith efforts to provide information that is accurate, we are not responsible for errors or omissions in information provided or conclusions reached as a result of using the specifications. By using the information provided, the user assumes all risks in connection with such use.