

# PIZZA PREP TABLE

**MODEL: PPT 67 21**

# PRO-KOLD

## Product features

- Extra deep, removable poly prep surface to handle food and prep properly
- (9) removable, poly-carbonate inserts
- Digital control for easy read-out and temperature adjustment
- (1) adjustable, interior shelves for storage
- Easy to clean stainless steel floor
- Casters included for maintaining cleanliness under and around unit
- Forced air refrigeration system to promote even cooling throughout food product
- Removable top rail cover lid
- Injected with high density polyurethane foam with cyclopentane



## Available Color

STAINLESS  
STEEL

## Accessories

- Additional shelves

## Product highlights



Fluorescent lighting



Intelligent temperature control



Easy access to condensing unit

## Certifications



SAFETY AND SANITATION  
ETD  
Conforme  
a UL-471



Conforme  
a NSF-7



## Warranty

- 2 year parts and labor
- Additional 3 year compressor coverage

Residential: Assumes on liability for parts or labor coverage for component failure, factory defect or any other damages for units installed in non-commercial foodservice or residential applications.

## PRODUCT SPECIFICATIONS

### MODEL: PPT 67 21

## Plan view

Front view

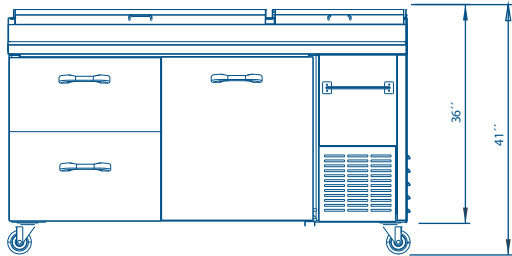

Top view

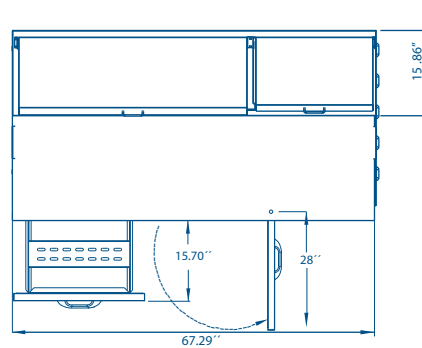

Side view

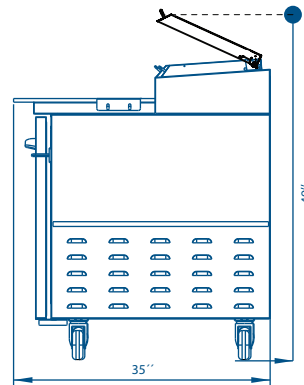

## Technical data

### Dimensions

External dimensions	W: 67.29" D: 35" H: 41"
Internal dimensions	W: 52.40" D: 29.37" H: 28.12"
Net volume	22.45 ft <sup>3</sup> (363 Lts.)
Net weight	433.42 Lbs.
Gross weight	485 Lbs.
Packaging dimensions	W: 69.40" D: 37.24" H: 43.62"

### Performance data

Refrigerant charge	7.05 oz
Energy consumption	8.308 kwh / 24 hr
Condenser	Ventilation forced
Evaporator	Ventilation forced
Evaporation temperature	19.94°F
Expansion method	Capilar
Thawing method	By time

### Construction

Exterior material	Stainless steel
Interior material	Stainless steel floor
Number of shelves	1
Shelf material	Pre painted steel
Door type	Stainless steel door
Door quantity	1
Drawers quantity	2

### Electrical data

Power supply	110v/ 60 Hz
Amps	7.29
Length of cord	118" (3000mm)
Lighting	Fluorescent
Plug type	NEMA-5-15P
Controller	Digital
Compressor power	1/3 HP

### Cooling

Temperature range	36°F to 41°F (Exhibition)
Refrigerant	R134a
Defrosting	Automatic
Temperature controller	Digital
Optimum temperature range	36°F to 41°F (Storage)

### Logistic data

Trailer Loads	32 fit on a 53' trailer
Unit weight with packaging	485 Lbs.
Dimensions with packaging	W: 69.40" D: 37.24" H: 43.62"

\* W= Width, D= Depth, H= Height