



ITEM #: _____ QTY: _____
 MODEL #: _____
 PROJECT NAME: _____

022418

3601 S. Banker St. Effingham, IL 62401 • P.O. BOX 609 • Ph: (888) 431-2667 • Fax: (800) 433-2667

"OC" OAK TABLE

FEATURES:

- APPALACHIAN RED OAK FINGER JOINTED TOP
- STANDARD BOOS BLOCK CREAM FINISH WITH BEESWAX
- SEE BASE COLOR SPEC SHEET FOR COLOR OPTIONS
- OPTIONS:
 PAINTED 1 OR 2 SLATTED LOWER SHELVES
 PAINTED UTENSIL DRAWER: CU-D14P (NOTE: 2 DRAWERS AVAILABLE ON 60" LENGTH ONLY)
 2-1/2" COMMERCIAL GRADE LOCKING CASTERS: CAS03
 BASKET: DWB8156
- OPTIONAL CASTERS ADD (-C), ADDS 2-1/2" TO H
- OPTIONAL 2 SHELVES ADD (-2S)



OC4825-D-2S-BK

OPTIONAL ACCESSORIES:



DWB8156



CAS03

OAK TABLE

NO SHELF	QTY	1 SHELF	QTY	2 SHELVES	QTY
OC3625		OC3625-S		OC3625-2S	
OC4825		OC4825-S		OC4825-2S	
OC6025		OC6025-S		OC6025-2S	
OC4830		OC4830-S		OC4830-2S	
OC6030		OC6030-S		OC6030-2S	
OC4836		OC4836-S		OC4836-2S	
OC6036		OC6036-S		OC6036-2S	

DETAILED SPECIFICATIONS

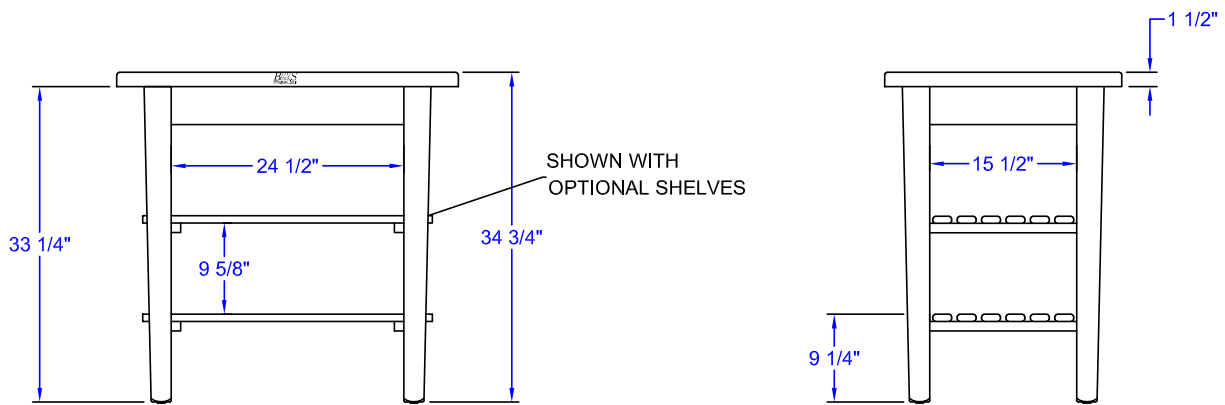
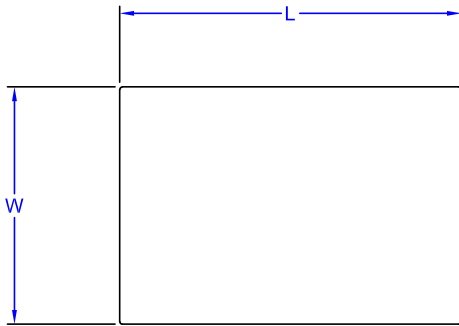

OAK TABLE

W X L	NO SHELF	WT. (LBS)	1 SHELF	WT. (LBS)	2 SHELVES	WT. (LBS)
36" X 25"	OC3625	57	OC3625-S	77	OC3625-2S	97
48" X 25"	OC4825	70	OC4825-S	95	OC4825-2S	120
60" X 25"	OC6025	82	OC6025-S	112	OC6025-2S	148
48" X 30"	OC4830	78	OC4830-S	109	OC4830-2S	140
60" X 30"	OC6030	93	OC6030-S	130	OC6030-2S	157
48" X 36"	OC4836	95	OC4836-S	127	OC4836-2S	159
60" X 36"	OC6036	110	OC6036-S	150	OC6036-2S	192

SOME UNITS SHIP UNASSEMBLED FOR REDUCED SHIPPING COST. ALL DIMENSIONS ARE TYPICAL. TOLERANCE +/- .500"
 John Boos & Co. is constantly engaged in a program of improving products and therefore reserves the right to change specifications without prior notice.



3601 S. Banker St. • Effingham, IL 62401 • PO BOX 609 • quotes@johnboos.com

050818

www.johnboos.com

167