



Project _____
 Item _____
 Quantity _____
 CSI - 11400 _____
 Approval _____
 Date _____



Admiral 44 Advanced VG Single Tank Rack Conveyor Dishwasher with Optional VaporGuard System

- Automatic conveyor, rack type, single tank dishwasher with recirculating wash and fresh water final rinse
- 0.63 gallons per rack at 20 PSI
- Capacity is 233 (20" x 20") racks per hour or 5,825 dishes per hour
- **VaporGuard** Condensation Removal System
- Telescoping doors allow for efficient daily cleaning
- Dual IS Booster System built into the machine
- No hood required (Refer to your local building code)

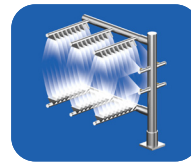

CrossFire Wash System power sprays water horizontally, as well as, from above and below, cleaning and sanitizing the dirtiest of ware.

STANDARD FEATURES

- CrossFire Wash System
- Color-coded curtains
- Tank heat: integrated booster
- Heat and energy saving transfer system
- Manifold clean-out brush
- S/S 304 stainless steel construction
- Automatic tank fill
- Low water protection
- Single point electrical connection: motor, controls and tank heat
- Detergent connection provision
- Elevated top mounted control panel
- Door safety switches
- Standard frame drip proof motors
- Override switch for de-liming
- SureFire Start-Up & Check-Out Service
- Ventilation fan connection provision
- End caps/pipe plugs secured to prevent loss
- VFD controlled continuous drive conveyor

OPTIONS

- Tank heat:
 - Electric
 - Steam coil
- Pressure reduction valve and line strainer
- Vent cowl collar with adjustable damper controls
- Security package
- Rack limit switch
- Power Loader
- Power Unloader
- Plastic 20" x 20" racks (plate or silver)
- Two point connection

SPECIFIER STATEMENT

Specified unit will be an Insinger Admiral 44 Advanced VG single tank, rack conveyor dishwasher with optional VaporGuard system. Features include VaporGuard condensation removal, CrossFire wash system, S/S 304 stainless steel construction, automatic tank fill, low water protection, elevated top mounted control panel, SureFire Start-Up & Check-Out service, and a VFD controlled continuous drive conveyor.



Additional Information

Capacity Per Hour	234 racks 5225 dishes 200-400 meals
Tank Capacity	19.9 gals. (pre-wash) 33.75 gals. (wash)
Motor Size	2 hp (wash) 1/15 hp (conveyor)
Electric Usage	18 kW built in booster 40° rise 29.4 kW built in booster 70° rise
Final Rinse Peak Flow at 20 psi min.	2.5 gallons/minute
Final Rinse Consumption at 20 psi min.	147 gallons/hour 0.63 gallons/rack
Peak Rate Drain Flow	9 gallons/minute
Installation distance from vertical combustible surface	2"
Shipping Weight	900 lbs.

SPECIFICATIONS

VAPORGUARD - Removes the heat and steam from the warewasher's exhaust vents and returning room temperature air to the surrounding space. The steam and water vapor are cooled and condensed then sent to the drain to reduce drain water temperature.

CONSTRUCTION- Hood and tank constructed of 16 gauge type 304 S/S. Hood unit of all welded seamless construction. S/S frame, legs and feet. All internal castings are non-corrosive lead free nickel alloy, bronze or S/S.

DOORS- Zero-Infringement Doors are extra large die formed, type 304 S/S, front inspection doors. The vertically opening doors glide in full length tracks on either side. Automatic safety catch at full open locations.

CONVEYORS- One S/S roller chain conveyor, with rack driving dogs every sixth link, running along the rear of the machine. Eight free spinning rollers placed along the front wall of the machine. Conveyor accommodates all standard 20" racks. Conveyor drive system includes direct drive gear motor powered by UFP to guarantee proper speed. Racks conveyed automatically through washing and rinsing systems, powered by an independent 1/15 hp drive motor.

PUMP- Centrifugal type "packless" self draining pump. Construction includes ceramic seal and a balanced cast stainless steel impeller on a precision ground stainless steel shaft, extension or sleeve. 2 hp motor, standard vertical C-face frame, drip proof, internally cooled with ball-bearing construction

CONTROLS- Top mounted control enclosure, housing motor overload protection, contactors, transformers and all other dishwasher controls. All controls safe low voltage 24 VAC.

ENERGY SAVER- Rack actuated lever automatically operates the final rinse solenoid only when a rack passes, saving water and energy. The lever also activates an adjustable timer control. If no ware passes during the set time, the machine shuts down.

SPRAY SYSTEM- Spray arms made of type 304 stainless steel pipe. Spray assemblies removable without the use of tools.

WASH- Upper and lower manifolds with the patented CrossFire® Wash System. One manifold above with 3 power wash arms, each with 5 high pressure cleaning slots and one manifold below with 4 power wash arms, each with 7 high pressure cleaning slots. The slots are precision milled for water control producing a fan spray. Wash arms are fillet welded to the S/S manifold. The CrossFire® Wash System provides 2 horizontally spraying high pressure nozzles.

FINAL RINSE- High efficiency CNC machined nozzles located in an optimal configuration for rinsing and heat transfer. Nozzle assemblies produce a fan spray reducing water consumption while maximizing heat retention.

DRAIN- Foot-operated drain lever. Energy saving bottom skimming overflow system. Heater is protected by low water level control.

Note: Exhaust requirements are for pant leg connections only. For hood type, CFM requirements vary, consult hood manufacturer for specific sizing.

Contact Insinger Sales at 800-344-4802 for an installation drawing specific to your application.

Note: Due to product improvement we reserve the right to change information and specifications without notice.

Technical Drawings and Electrical

ADMIRAL 44 ADVANCED R-L with VAPOR GUARD OPTION High Temperature Rack Conveyor Electrically Heated Dishwashing Machine

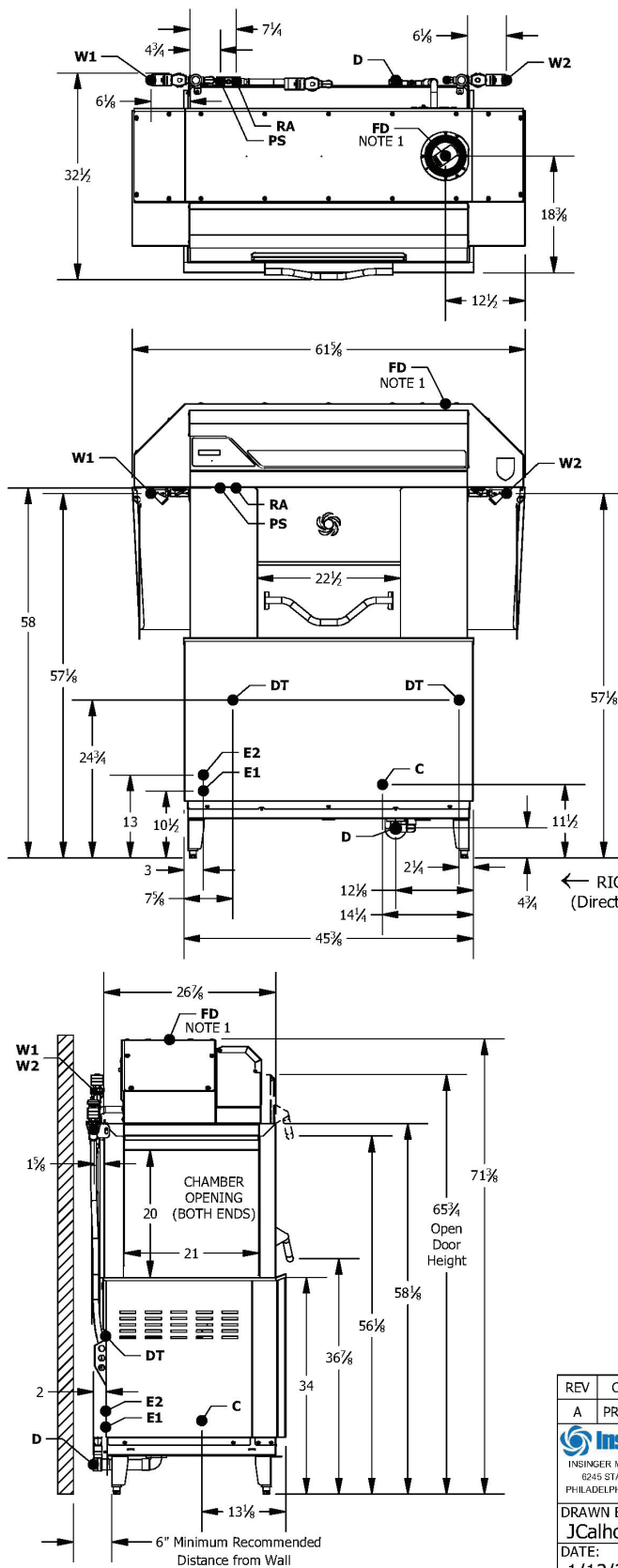

INSTALLATION CONNECTIONS		
	Description	Note
D	DRAIN CONNECTION	1-1/2 FPT
W1	HOT WATER INLET (110° F MIN.)	1/2 FPT
W2	COLD WATER INLET (80° F MAX.)	1/2 FPT
E1	MAIN ELECTRICAL (SINGLE & 2-POINT)	1-3/8 HOLE
E2	BOOSTER ELECTRICAL (2 PT ONLY)	1-3/8 HOLE
C	CONDUCTIVITY PROBE LOCATION	7/8 HOLE
DT	DETERGENT INSERSION POINTS	7/8 HOLE
PS	PRESSURE SWITCH CONNECTION	1/4 FPT
RA	RINSE AID CONNECTION	1/4 FPT
FD	VAPOR GUARD FAN DISCHARGE	(NOTE 1)

SPECIFICATIONS	
Racks per Hour	234
Dishes per Hour	5225
Meals per Hour	200-400
Wash Tank (gallons)	33.75
Drive Motor HP	1/15
Wash Motor HP	2
Water Consumption @ 20 psi (gal / hr)	147
Gallons per Rack @ 20 psi	.063
Vapor Guard Water Consumption @ 20 psi (gpm)	4.0
Peak Drain Flow (gpm)	9.0
Tank Heat (kW)	18.0
Booster Heat (kW)	29.4
Shipping Weight (lbs)	900

SINGLE POINT ELECTRICAL CONNECTION			
Voltage	(E1) Rated Amps	(E1) Min. Circuit Ampacity / Max. Protective Device	
208/60/3	141.3	200	
240/60/3	123.7	175	
480/60/3	63.7	90	

DUAL POINT ELECTRICAL CONNECTION				
Voltage	(E1) Rated Amps	(E1) Min. Circuit Ampacity / Max. Protective Device	(E2) Rated Amps	(E2) Min. Circuit Ampacity / Max. Protective Device
208/60/3	59.7	80	81.6	110
240/60/3	53.0	70	70.7	90
480/60/3	28.3	40	35.4	45

- NOTES:
1. ALLOW 6" MINIMUM CLEARANCE ABOVE THE VENT FAN DISCHARGE
 2. ALLOW 24" MIN. CLEARANCE BELOW DISH TABLE TO SERVICE ELECTRICAL EQUIPMENT

NOTE: Total amp is calculated by adding machine amp and booster amp together
 *Machine may be ordered with two point connection to separate booster electrical connection

REV	CHANGE	DESCRIPTION	DATE	APPROVED
A	PROCESS	RELEASED TO PRODUCTION	1/20/2022	JSC
DESCRIPTION: Spec Sheet, AA-44 R-L with Vapor Guard Option				
DRAWN BY: JCalhoun		SHEET SIZE: A		PART NUMBER: 9200-03576
DATE: 1/13/2022		REV: A		SHEET 1 of 1

Technical Drawings and Electrical

ADMIRAL 44 ADVANCED L-R with VAPOR GUARD OPTION High Temperature Rack Conveyor Electrically Heated Dishwashing Machine

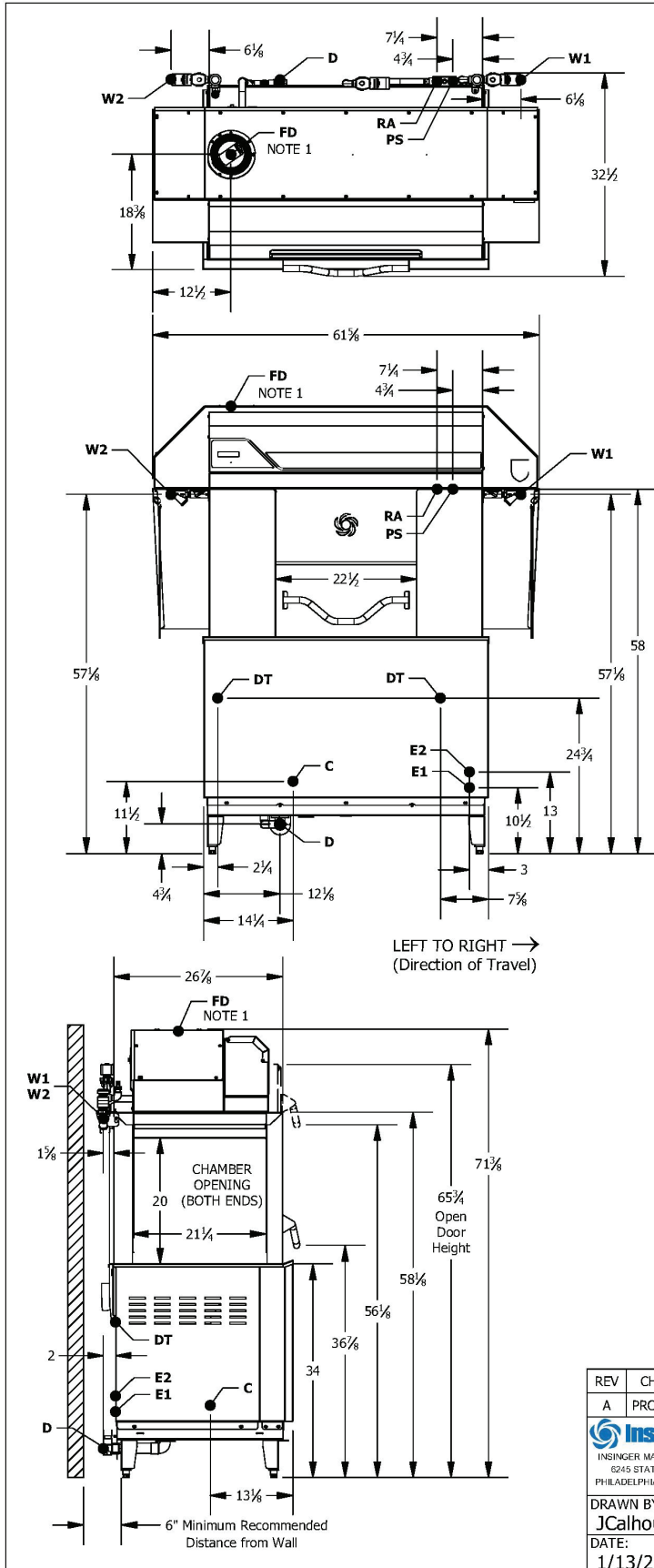

INSTALLATION CONNECTIONS		
	Description	Note
D	DRAIN CONNECTION	1-1/2 FPT
W1	HOT WATER INLET (110° F MIN.)	1/2 FPT
W2	COLD WATER INLET (80° F MAX.)	1/2 FPT
E1	MAIN ELECTRICAL (SINGLE & 2-POINT)	1-3/8 HOLE
E2	BOOSTER ELECTRICAL (2 PT ONLY)	1-3/8 HOLE
C	CONDUCTIVITY PROBE LOCATION	7/8 HOLE
DT	DETERGENT INSERSION POINTS	7/8 HOLE
PS	PRESSURE SWITCH CONNECTION	1/4 FPT
RA	RINSE AID CONNECTION	1/4 FPT
FD	VAPOR GUARD FAN DISCHARGE	(NOTE 1)

SPECIFICATIONS	
Racks per Hour	234
Dishes per Hour	5225
Meals per Hour	200-400
Wash Tank (gallons)	33.75
Drive Motor HP	1/15
Wash Motor HP	2
Water Consumption @ 20 psi (gal / hr)	147
Gallons per Rack @ 20 psi	.063
Vapor Guard Water Consumption @ 20 psi (gpm)	4.0
Peak Drain Flow (gpm)	9.0
Tank Heat (kW)	18.0
Booster Heat (kW)	29.4
Shipping Weight (lbs)	900

SINGLE POINT ELECTRICAL CONNECTION			
Voltage	(E1) Rated Amps	(E1) Min. Circuit Ampacity / Max. Protective Device	
208/60/3	141.3	200	
240/60/3	123.7	175	
480/60/3	63.7	90	

DUAL POINT ELECTRICAL CONNECTION				
Voltage	(E1) Rated Amps	(E1) Min. Circuit Ampacity / Max. Protective Device	(E2) Rated Amps	(E2) Min. Circuit Ampacity / Max. Protective Device
208/60/3	59.7	80	81.6	110
240/60/3	53.0	70	70.7	90
480/60/3	28.3	40	35.4	45

- NOTES:
1. ALLOW 6" MINIMUM CLEARANCE ABOVE THE VENT FAN DISCHARGE
 2. ALLOW 24" MIN. CLEARANCE BELOW DISH TABLE TO SERVICE ELECTRICAL EQUIPMENT

NOTE: Total amp is calculated by adding machine amp and booster amp together
*Machine may be ordered with two point connection to separate booster electrical connection

REV	CHANGE	DESCRIPTION	DATE	APPROVED
A	PROCESS	RELEASED TO PRODUCTION	1/20/2022	JSC
 DESCRIPTION: Spec Sheet, AA-44 L-R with Vapor Guard Option				
DRAWN BY: JCalhoun		SHEET SIZE: A		PART NUMBER: 9200-03575
DATE: 1/13/2022		REV: A		SHEET 1 of 1