

# ATMOVAC

A COMPLETE RANGE OF SOUS-VIDE COOKING SOLUTIONS

**SV-96**  
MADE IN CHINA

## THERMAL IMMERSION CIRCULATORS FOR SOUS-VIDE

With volume capacity from 25 liters (6.6 gallons) to 60 liters per unit (15.6 gallons) our ATMOVAC units will deliver precise temperature control over time in all conditions.

- Precise temperature and time control
- Adapts to a variety of containers.
- Sous-Vide cooking or Precise Rethermalization in Cook and Chill processes
- Perform pasteurization processes for maximum shelf live and sale opportunity
- No direct contact with air or water extends life of foods and provides maximum safety
- Save on energy consumption compared to oven or gas stove



**ALSO AVAILABLE FROM ATMOVAC**



**SV-120**  
MADE IN CHINA



**SV-310**  
MADE IN CHINA



**SOFTCOOKER XP 120/230**  
MADE IN ITALY

# ATMOVAC

SV-96	
<b>POWER</b>	120V, 900W, 7.5A
<b>NEMA</b>	5-15P
<b>MINIMUM WATER LEVEL</b>	4.25"
<b>MAXIMUM WATER LEVEL</b>	6.5"
<b>MAXIMUM VOLUME CAPACITY</b>	8 Gal (30L)
<b>WATER CIRCULATION RATE</b>	1.2 Gal/min (4.5 L/min)
<b>TIMER RANGE</b>	5 mins - 99 hrs
<b>TEMPERATURE RANGE</b>	5 - 95°C
	41 - 203°F
<b>TEMPERATURE VARIANCE (+/-)</b>	0.1°C
	0.1°F
<b>AUTO SHUT-OFF</b>	NO
<b>DIMENSIONS (L X W X H)</b>	6.25" x 4" x 13.25"
<b>NET WEIGHT</b>	4 lbs
<b>SHIPPING DIMENSIONS (L X W X H)</b>	15.75" x 15" x 14.75"
<b>SHIPPING WEIGHT</b>	11 lbs

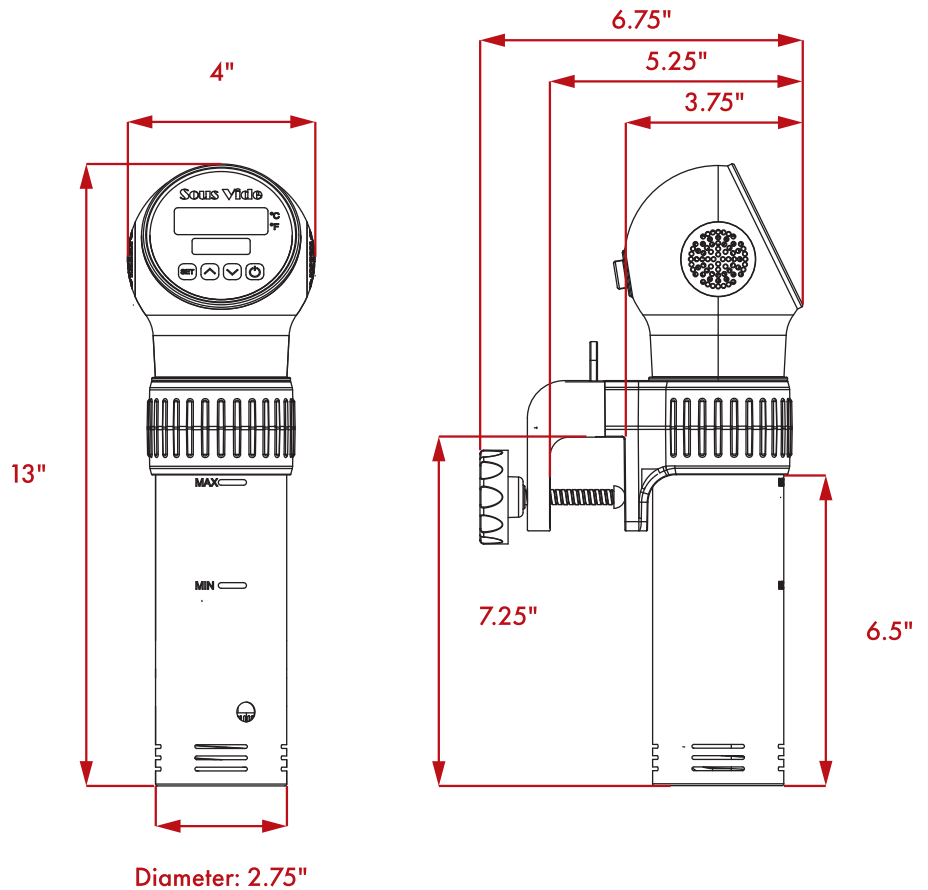

## FEATURES:

- Temperature and Time Controls
- Adjustable fixed clamp
- Removable filter for easy cleaning
- IPX7 certified waterproof

## SAFETY FEATURE:

- Dry-Run Protection
- Element protective cell
- Protection against overvoltage and overheating

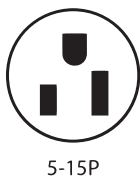

V2.12.2021



Please consult our website [www.eurodib.com](http://www.eurodib.com) for additional information on our product lines.  
 US 334 Cornelia St., Suite #272, Plattsburgh, NY 12901 | CAN 120 rue de la Barre, Boucherville, QC, J4B 2X7  
 1 888 956 6866 | [info@eurodib.com](mailto:info@eurodib.com) | [www.eurodib.com](http://www.eurodib.com)