

## TROLLEY WITH SHELVES

FOR TABLE-TOP MODELS



### FEATURES

- Dimensions (l x w x h)  
23.6" x 19" x 26.5"
- Weight 17 kg (37.4 lb)
- Full stainless steel
- Swiveling castors with brakes
- Extended mobility
- Shelves to store printer, labels, pouches and other accessories
- Optimal use of space
- Suitable for ALL countertop units of the ATMOVAC range except Chinook16D

### DESCRIPTION

The universal cart is suitable for ALL countertop units of the ATMOVAC range except Chinook16D. It is ideal to increase the machine, to store a printer, accessories, labels your space optimally.

# ATMOVAC TROLLEY WITH SHELVES – SPECS

TROLLEY WITH SHELVES – SPEC SHEET

## DIMENSIONS

In mm

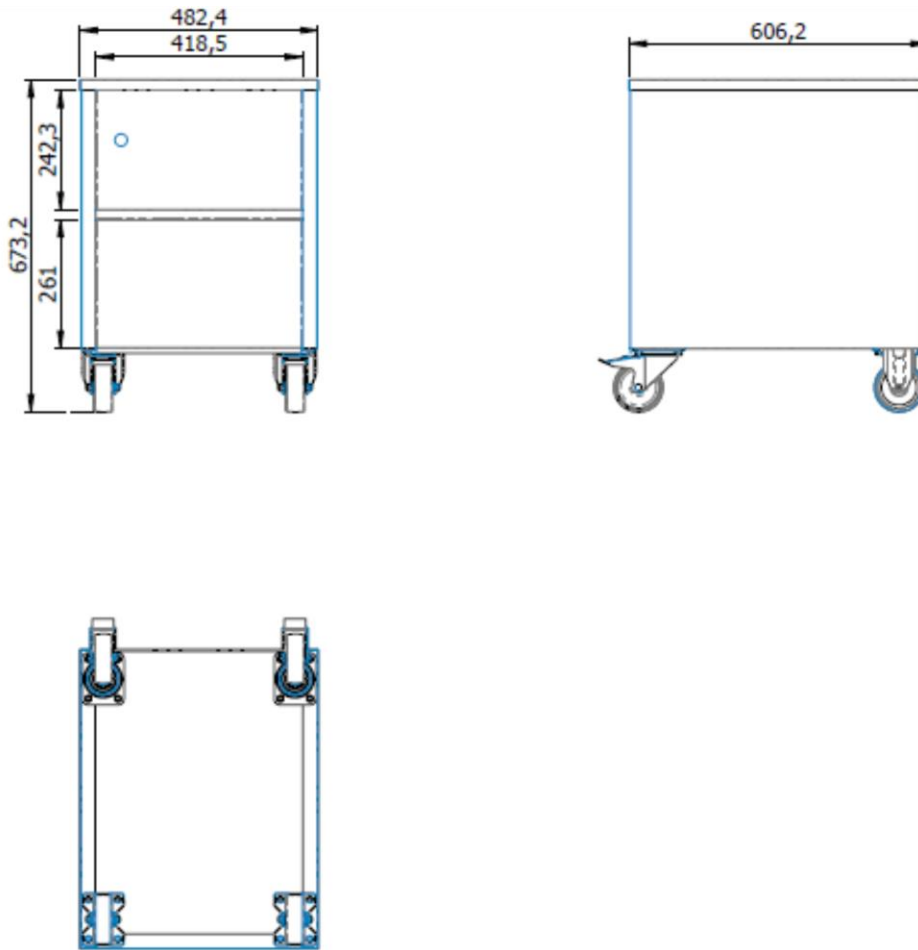

	L x W x H (IN)	Weight (lb)
Dimensions	23.6 x 19 x 26.5	37.4

**ATMOVAC**

**Eurodib**  
 US 334 Cornelia St #272, Plattsburgh, NY  
 CAN 120 rue de la barre, Boucherville, Qc J4B 2X7  
 1-888-956-6866 | [info@eurodib.com](mailto:info@eurodib.com)  
[www.eurodib.com](http://www.eurodib.com)