

Refrigerated Glass Door Merchandisers

Plan Views

USRFS-1D/22

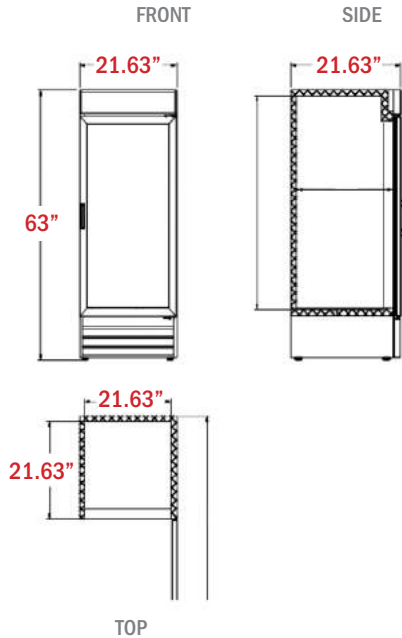

USRFS-2D/54

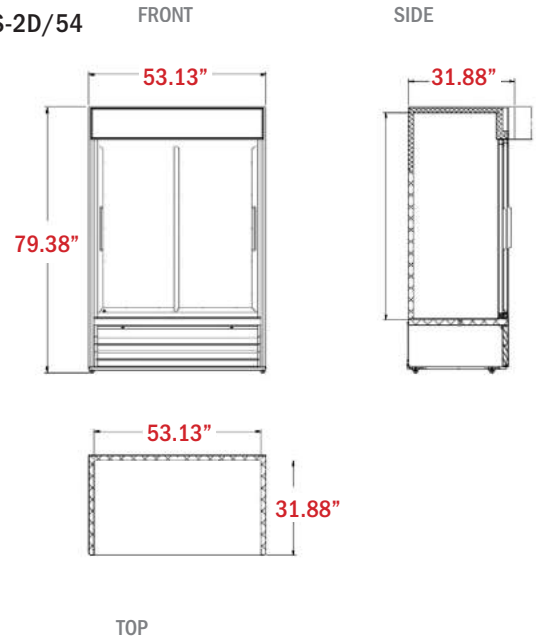

Features

Refrigeration System

- Environmentally-friendly R290 refrigerant
- Bottom-mounted cooling unit slides out for easy cleaning and maintenance, and allows for extra storage on top of unit
- Maintains temperature range of 32° – 41° F
- Rugged built axial evaporator fans run efficiently, with low velocity and high volume air flow

Electrical Control

- Front LED temperature display for easy viewing of internal temperature
- Temperature controller initiates automatic defrost schedule for worry free use
- 7-foot power cord with NEMA 5-15 plug



Cabinet Construction

- Black-coated steel exterior for a sleek appearance
- Painted aluminum interior allows for easy cleaning
- Insulated throughout with foamed-in-place high density cell polyurethane insulation

Door(s)

- Large glass doors that provide high visibility with anti-fogging.
- Positive self-closing doors with microswitch that shuts the evaporator fans off when the door is open
- Self-closing doors keep the cold air in and keeps internal temperature constant
- Removable door gasket for easy cleaning

Shelving

- Adjustable plastic-coated steel shelves that have a load capacity of up to 90 lbs per shelf

Model Features

- Interior lighting provides greater visibility for merchandising
- Colorful, lighted graphics on top of the unit helps to draw in customers