

FEATURES

- Digital controls
- Microprocessor controls regulate refrigeration
- Low mix indicator light
- Counter records number of dispenses
- Standby mode
- Hopper agitator to maintain mix consistency
- Air cooled
- Perfect for soft-serve ice cream, custard, yogurt or sorbet



LIIC-1H



LIIC-2H/CT



LIIC-2H



MODEL #	LIIC-1H	LIIC-2H/CT	LIIC-2H
Type	Countertop	Countertop	Floor
Flavors	1	2	2
Feed	Gravity	Gravity	Gravity
Cooling	Air Cooled	Air Cooled	Air Cooled
Freezing Cylinders	1 x 1.9 qt	2 x 1.9 qt	2 x 1.9 qt
Mix Hoppers	1 x 11.6 qt	2 x 13.2 qt	2 x 13.2 qt
Output	19 qt / hr	50.7 qt / hr	50.7 qt / hr
Motor	1 x 1.25HP	2 x 1.25HP	2 x 1HP
Compressor (Main)	1 x 3100 BTU/hr, R404a	2 x 3393 BTU/hr, R404a	2 x 3393 BTU/hr, R404a
Compressor (Auxillary)	1 x 400 BTU/hr, R134a	1 x 400 BTU/hr, R134a	1 x 400 BTU/hr, R134a
Voltage/Hertz/Phase	220/60/1	220/60/1	220/60/1
Amps	8	20	20
Net Weight (lbs)	231.5 lbs	441 lbs	474 lbs
Gross Weight (lbs)	264.5 lbs	496 lbs	518 lbs
Overall Dimensions (in.)	17.3"W x 32"D x 31.3"H	22"W x 31.6"D x 42"H	22"W x 25.7"D x 60"H
Shipping Dimensions (in.)	21"W x 33.5"D x 37.4"H	25.5"W x 37.5"D x 49.2"H	25.5"W x 31.5"D x 65.5"H

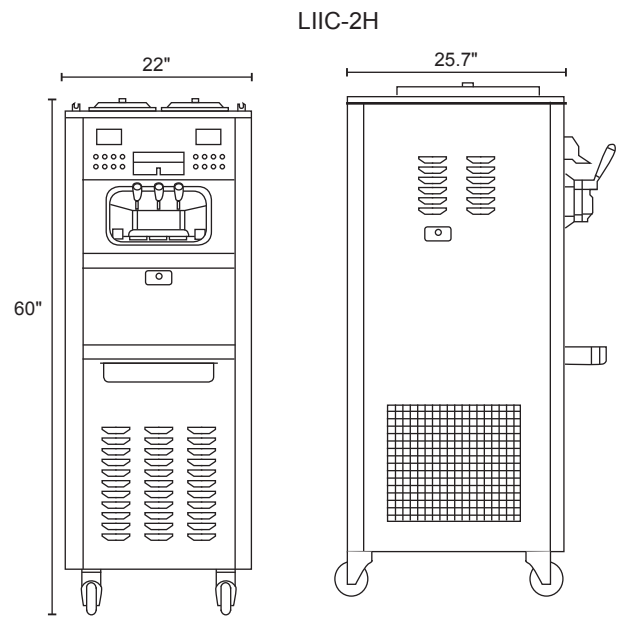
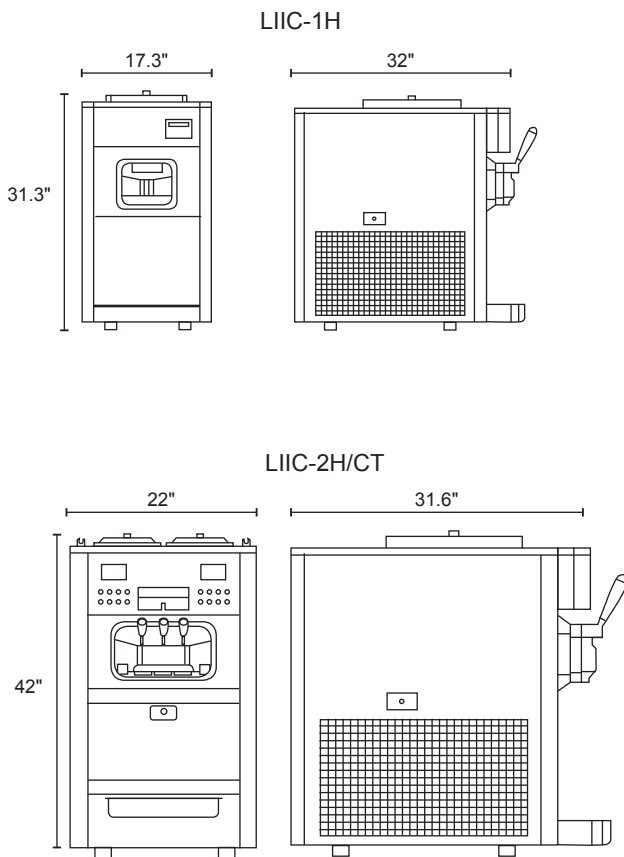

REFRIGERATION SYSTEM

- Main compressors utilize R404a refrigerant
- Separate hopper compressor for pre-cooling utilizes R134A refrigerant

MICROPROCESSOR CONTROLS

- Microprocessor regulates refrigeration by measuring product viscosity to maintain consistent quality

MIX LOW LIGHT

- The mix low light turns "ON" to alert operator to add mix
- Prevents cylinder from over-freezing

STANDBY MODE

- Maintains product temperature in mix hoppers and freezing cylinders below 39.9°F during long periods of not being used

COUNTER

- Records number of dispenses per day and total number of dispenses

AGITATOR IN HOPPER

- Ensure that the mixture maintains consistent liquidity and temperature



Warranty

These units are backed by a 1-year parts and labor warranty and a 5-year warranty on the compressor