

36" Heated Display

HD-36

- Double wall stainless steel construction allows outside of unit to remain cool
- Adjustable thermostat
- Illuminated interior for attractive merchandising
- Easily accessible for filling with front and rear sliding doors
- Convenient for customer self-service
- Easily adjustable shelves
- Internal humidifying system keeps food fresh for extended periods
- Attractive sleek design
- 120V, 1500W, 12.5 AMPS
- CE
- ETL Sanitation

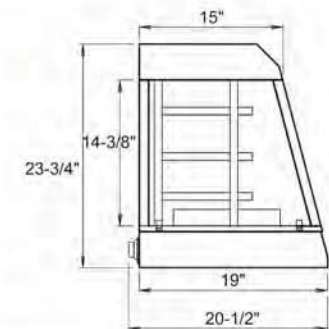
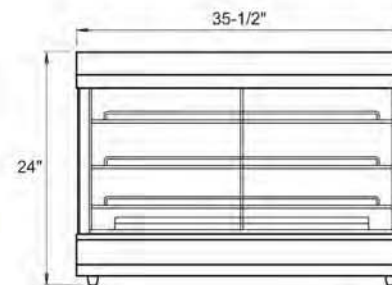

ADCRAFT

The more you look, the better we look.

Protected by Admiral Craft Equipment Corporation's one year limited warranty. Should your product fail under normal use, it will be repaired or replaced up to one year from date of purchase.

