



Undercounter Refrigerators



Grista's Undercounter Refrigerators are constructed of heavy duty stainless steel making them strong and durable enough to survive in any kitchen environment. These units are perfect for adding more storage space anywhere you need. The flat stainless steel countertop allows for them to be used as a separate workstation. All undercounter units come with 4" casters and plastic coated wire shelving. These models are ETL Listed and ETL Sanitation. They are backed with a 1 year warranty on parts and labor and a 5 year warranty on the compressor.

Product Features

- 430 series stainless steel exterior
- Painted aluminum interior
- Environmentally-friendly R290 refrigerant
- Precise digital temperature controller with LED display
- Foamed-in-place polyurethane high density cell insulation throughout the entire cabinet
- Automatic defrosting
- Removable door gasket
- Recessed door handles
- (4) 4" casters (2 locking and 2 non-locking)



GRUCRF-27



GRUCRF-48



Specifications

Model Number	GRUCRF-27	GRUCRF-48
Doors	1	2
Shelves	1	2
Net Volume (Cu. Ft.)	6.3 Cu. Ft	12 Cu. Ft
Overall Dimensions (in)	27"W x 29.5"D x 35.2"H	47.2"W x 29.5"D x 35.2"H
Interior Dimensions (in)	22"W x 23"D x 23.5"H	42.5"W x 23"D x 23.5"H
Horsepower	1/6	1/5
Refrigerant	R290	R290
Voltage/Hertz/Phase	115/60/1	115/60/1
Amps	1.9	2.7
Net Weight (lbs)	169 lbs	238 lbs
Gross Weight (lbs)	220 lbs	299 lbs
Shipping Dimensions (in)	29.7"L x 32.5"W x 38.5"H	50"L x 32.5"W x 38.5"H



Undercounter Refrigerators

Plan Views

GRUCFZ-27

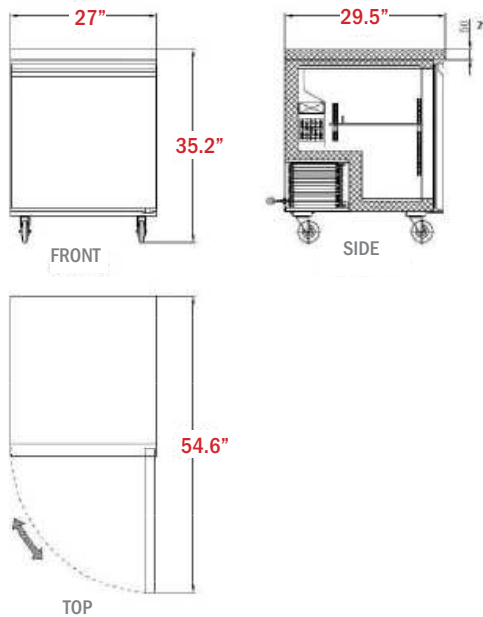

GRUCFZ-48

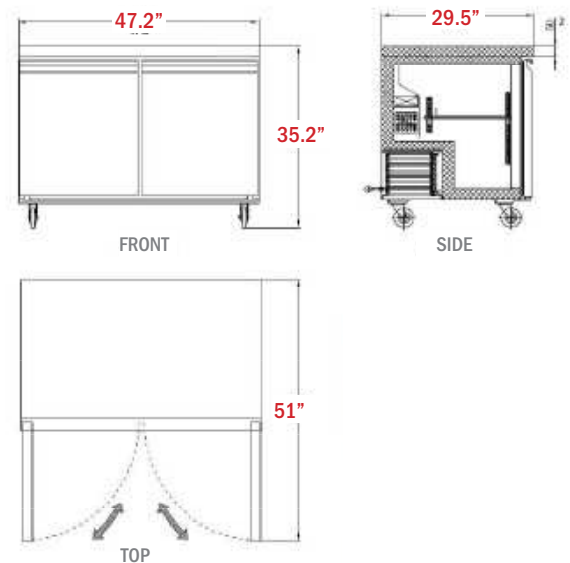

Features

Refrigeration System

- Refrigeration units use environmentally friendly R290 refrigerant
- Maintain a temperature range of 33°F–40°F
- Rugged built axial evaporator fans run efficiently with low velocity and high volume air flow

Electrical Control

- Electric LED temperature controller provides a digital display of cabinet temperatures and allows for easy temperature adjustments when necessary
- Temperature controller initiates automatic defrost schedule for worry free use
- 7 foot power cord with NEMA 5-15 plug



Cabinet Construction

- Exterior is constructed of 430 stainless steel including the doors
- The cabinet is insulated throughout with a foamed-in-place high density cell polyurethane insulation

Door(s)

- Stainless steel exterior with matching aluminum liner on the inside
- Positive self-closing doors with microswitch that shuts the evaporator fans off when the door is open
- Recessed handles are built into the door for easy opening and closing
- Removable door gasket for easy cleaning

Shelving

- Adjustable plastic coated steel shelves that have a load capacity of up to 90 lbs per shelf

Model Feature

- 4" casters come standard on all stainless steel models 2 locking and 2 non-locking.