

BLACK DIAMOND

G A S E Q U I P M E N T

BDECTC Series Specifications

Standard Radiant Gas Countertop Charbroilers

Black Diamond's Standard Series Radiant Gas Countertop Charbroilers are designed for use with either natural or LP gas. Constructed of stainless steel front and sides that are fully welded, these units are able to stand the toughest of kitchen environments. Each unit includes tips for field conversion to LPG.



This item meets the sanitation standards imposed by the ETL, a division of the Intertek Group.



This item meets the electrical product safety standards imposed by the ETL, a division of the Intertek Group, for use in the United States and Canada.



BDECTC-16/NG
BDECTC-24/NG
BDECTC-36/NG
BDECTC-48/NG

Plan Views

FRONT VIEW

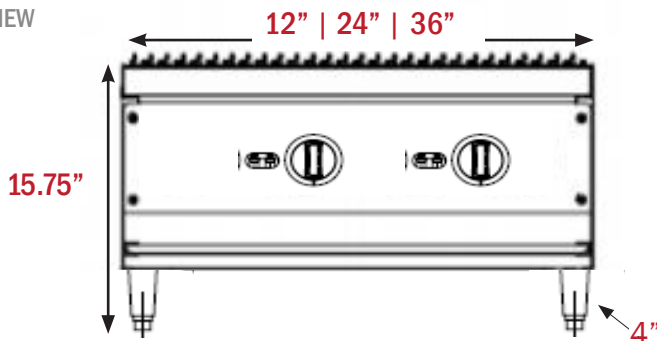

SIDE VIEW

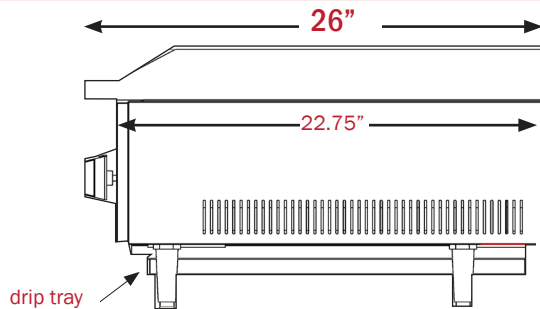

Features

- Fully welded stainless steel front bullnose design with galvanized sides
- Fully welded stainless steel backsplash for extra durability
- 30,000 BTU per burner
- One stainless steel burner every 12" grate width
- Cast iron grill grates are reversible and height adjustable
- 4"-5" adjustable legs
- Separate gas valves for each burner with standing pilot ignition system
- Removable stainless steel drip tray for easy cleaning
- 3/4" rear NPT gas inlet
- ETL Listed and ETL Sanitation

Drip Tray Dimensions

Model	Width	Depth	Height
BDECTC-16/NG	11.5"	21"	1"
BDECTC-24/NG	20.75"	20.75"	1"
BDECTC-36/NG	31.5"	20.75"	1"
BDECTC-48/NG	20"	20.75"	1.25"

Specifications

Model Number	BDECTC-16/NG	BDECTC-24/NG	BDECTC-36/NG	BDECTC-48/NG
Total BTU	30,000 BTU	60,000 BTU	90,000 BTU	120,000 BTU
Overall Dimensions (in)	15.75"H x 16"W x 26"D	15.75"H x 24"W x 26"D	15.75"H x 36"W x 26"D	15.75"H x 48"W x 26"D
Burners	1	2	3	4
Net Weight (lbs)	95 lbs	119 lbs	163 lbs	244 lbs
Gross Weight (lbs)	121 lbs	154 lbs	218 lbs	359 lbs
Drip Tray	1	1	1	2

Black Diamond warrants this product to be free of defects in materials and workmanship for period of 1 year from the date of original installation.